



Instructions for installation and use

WARNING!

- Do not cover the sauna heater. This creates a fire hazard.
- Do not touch the top of the heater. This will cause severe burns.
- Incorrect ventilation or an incorrectly located sauna heater can, under certain circumstances, cause excessive drying of the wood in the sauna and create a fire hazard.
- Cover sauna floors with a non-slip material.
- Never hose down the sauna.
- There must always be at least 1.7 in. insulation directly behind the wood panelling in the sauna (no other material may be used, such as particle board, plaster, etc).
- Sauna doors must always open outwards. All that should be needed to open the sauna door is just a little light pressure. Never provide the door with any locking or latching. Make sure that the door do not cause any entrapment.
- Do not use the sauna for any purpose other than sauna bathing.
- Do not install more than one sauna heater in a sauna room, unless you follow exactly the special instructions for twin-heater installations.
- Sauna fragrances, etc. may ignite if poured undiluted into the rock compartment.
- Never leave young children unattended in the sauna.
- Sauna bathing is not always suitable for persons in poor health. Consult your doctor for advice.
- Enjoy your sauna bath as long as it feels pleasant, prolonged exposure is capable of inducing hyperthermia*.
- Store this information in a safe place.

* **Hyperthermia** occurs when the internal temperature of the body reaches a level several degrees above the normal temperature of 98.6 °F. The symptoms of hyperthermia include an increase in the internal temperature of the body, dizziness, lethargy, drowsiness and fainting. The effect of hyperthermia include:

- Failure to perceive heat;
- Failure to recognize the need of exit the room;
- Unawareness of impending hazard;
- Fatal damage of pregnant women;
- Physical inability to exit the room; and
- Unconsciousness

WARNING - The use of alcohol, drugs, or medication is greatly increasing the risk of fatal hyperthermia.

Installation

Fig. 1.

Tylö SuperSport sauna heater with integral control panel.

Fig. 2.

Tylö Sport-U sauna heater with integral control panel.

Fig. 3.

Tylö Deluxe, SE-U sauna heater with separate TS or CC control panel (type SE-U only uses a CC panel).

Fig. 4.

Tylö Combi -U whit integral control panel - for private use only (in public saunas Tylarium/CC20/CC200/CC300T should be installed).

Installing the sauna heater.

The sauna heater should be placed on the same wall as the door, see figure 7. In an exceptional circumstance, the heater may be placed on a side wall, but as close as possible to the wall with the door. Fit the heater 10½ in. above the floor, observing the regulations for the minimum distance to the side wall. You can use the box which contains the sauna rocks to help you when installing Tylö heaters (not the Combi-U). When placed on its short end, the box is 10½ in. high.

Tylö sauna heaters are connected by a normal standard wire or cable approved for permanent installation. The cable or conduit is laid on the outside of any heating insulation; see figs. 10, 11 and 12. Single-core cables must be protecting by a flexible metal conduit up to the heater. When the heater has been installed, a set screw (I, figs. 11 and 12) locks it in place on the supporting brackets. This prevents the heater from being removed from the wall.

Important! The enclosed metal plate "Caution, Reduce the risk of fire." must be mounted on the interior wall adjacent to the heater. The enclosed metal plate "Warning, Reduce the risk of overheating." must be mounted on the outside of the room at about eye level where clearly visible.

Fig. 5 – Minimum safety distances.

A = standard installation. **B** = recess installation. Please refer to the table for minimum distances to side wall (X, Y). When installing Deluxe sauna heaters in a recess, the sensor (C) should be placed 10 in. from the rear wall of the recess and 59 in. above floor level.

Fig. 6 – Minimum safety distances.

Minimum distance to sauna fittings in front of a sauna heater.

Fig. 8 – Sauna.

(Sauna heater type Deluxe and control panel type CC). 1 = sauna heater. 2 = thermistor (sensor). 3 = control panel CC 10/ CC 50/ CC 100/CC 300. 4 = external power switch (if any). 5 = distribution box. 6 = relay box RB30/60.

Fig. 9 – Sauna.

(Sauna heater type SE-U and control panel type CC).

1 = sauna heater. 2 = thermistor (sensor). 3 = control panel CC 10/ CC 50/ CC 100/CC 300. 4 = external power switch (if any). 5 = distribution box.

Fig. 10 – Combi - U

A = electric conduit. **B** = wooden panel. **C** = insulation. **D** = built-in sensor. **E** = built-in control panel. **G** = vent. **H** = wooden batten. **I** = set screw. **J** = temperature limit control (in the reservoir). **K** = drainage pipe. **L** = Hanging console.

Fix the hanging console at a minimum distance (M) of 180 mm (7.1 in) from the side wall and 675 mm (26.6 in) above floor level (N).

Fig. 11 – SuperSport, Sport-U.

A = electric conduit. **B** = wooden panel. **C** = insulation. **D** = built-in sensor. **E** = built-in control panel (Supersport). **E** = built-in control panel (Sport-U). **G** = vent. **H** = wooden batten. **I** = set screw.

Fig. 12 – Deluxe.

A = electric conduit. **B** = wooden panel. **C** = insulation (behind control panel). **D** = sensor. **E** = TS separate control panel (CC panel in folded figure). **F** = capillary tube/thermistor wire **G** = vent. **H** = wooden batten. **I** = set screw.

Amperage and conductor area:

Model	Output kW	Voltage / Amps	AWG
SU 2/4	2,2	115V1~ 240V1~	10* 14*
SU 2/4	4,5	240V1~	10*
SU 7, AU 7, CU 7	5,3	208V1~/ 26A ***208V3~/ 20A	10* 10*
SU 7, AU 7, CU 7	7	240V1~/ 30 A ***240V3~/ 17 A	8* 10*
SU 8, AU 8, CU 8	6,3	208V1~/ 30A ***208V3~/18A	8* 10*
SU 8, AU 8, CU 8	8,3	208V3~/ 23 A 240V1~/ 35 A ***240V3~/ 20 A	10* 8* 10*
AU 11	10,7	240V1~/ 45 A 208V3~/ 30 A	6* 8** 8* 10**
AU16	16	208V3~/ 45 A	6* 8**

*) Min. copper wire size, supply power - control panel

**) Min. copper wire size, control panel - heater.

**) Model SU and CU is only available in single phase.

Sauna volume and min. installation distances:

Output kW	Sauna volume min/max cu.ft.	Min. distance from side wall (in.)		Minimum ceiling height in sauna (in.)
		normal installation "X"	recess installation "Y"	
2,2-4,5	70-210	4	8	74
5,3 - 7	140 -320	4	8	74
6,3 - 8	175 - 440	4	8	74
10.7	320-640	6	8	74
16	586-1080	6	14	83

Sauna heater – separate control panel combinations

Heater type	Suitable control panel	
	240 V 1~	208 V 3~
Deluxe 7-8-11	TS 30-01, CC/RB 30	TS 30-01, CC/RB 30
Deluxe16	-	CC/RB 60
SE-U 7-U8	CC	-

Installation of separate control panels.

A separate control panel is required for the Tylö Deluxe and SE-U heaters. The control panel must be assembled outside the sauna.

TS-type control panels

TS panels are thermally operated and have a patented divided output. They can either be mounted on the wall or recessed for a flush fit (fig. 12). It is essential to fit insulation behind control panels recessed into the wall. The standard length of the capillary tube is 73 in., but a 197 in. capillary tube is also available. Installing a sensor for a TS control panel (fig. 13). **A** = capillary tube. **B** = sensor holder. **C** = plastic holder for capillary tube. **D** = sensor that is installed 59 in. above floor level (fig. 12, not above the sauna heater).

Extra equipment for the TS control panel.

Locking cover in transparent plastic to fit over the control panel. Available in designs to prevent unauthorized interference with time and temperature settings, or temperature only.

Figs. 22, 23, 24, 25, 29 Wiring diagrams.

(With sauna heater Sport - U, Supersport and Combi - U with built-in control panels).

1 = sauna heater.

Check the heater's type identification plate to ensure that the heater is connected to the right voltage.

Don't forget – The installation must be earthed!

Figs. 26, 30 Wiring diagrams.

(With sauna heater Deluxe and control panel TS).

1 = sauna heater. 2 = control panel.

Check the heater's type identification plate to ensure that the heater is connected to the right voltage.

Don't forget – The installation must be earthed!

Remote control operation.

TS control panels use contactors for remote control operation. Please request special wiring diagram.

CC control panels.

Instructions: included with the control panel.

Can be installed at any distance from the sauna room.

CC panels are electronically operated and are available in the following models:

CC 10-1. Manual and automatic on/off. A maximum of one hours' running time, 10 hours' pre-set time.

CC 50-1. Manual and automatic on/off. A maximum of one hours' running time, 10 hours' pre-set time.

CC 100-1. Manual and automatic on/off. A maximum of one hours' running time, 24 hours' pre-set time.

CC 100-0. Built-in weekly timer. A maximum of 12 hours' continuous running time.

CC 300. Built-in weekly timer. Manual and automatic on/off. A maximum of 24 hours' running time, 24 hours' pre-set time.

Placement of the thermistor (sensor).

59 in. above floor level (not above the sauna heater).

The thermistor wire can be lengthened outside of the sauna with a partially enclosed low-voltage cable (2-core).

The thermometer in the sauna should be placed at a height so that the temperature corresponds exactly to the numbers displayed on the CC 50/CC 100/CC 300.

Relay box (RB).

(No relay box is used for SE-U heaters).

Installed outside the sauna at any distance from it. The relay box may not be placed closer than one meter from the CC 10/ CC 50/ CC 100/CC 300.

Partially enclosed low-voltage cable (6-core, LiYCY).

The control cable between the CC 10/ CC 50/ CC 100/CC 300 and the relay box or SE-U heater must be a partially enclosed low-voltage cable (6-core, LiYCY).

Connect the shielding cable to plinth 12 in the CC-panel.

Lighting.

(Not CC 10)

Connect the lighting according to the wiring diagram.

Remote control operation.

CC control panels are already prepared for remote-control operation from one or more locations.

Option: external on/off-switch (instantaneous).

Can be placed at any distance from the sauna. Connected with a low-voltage cable to the CC 10/ CC 50/ CC 100/ CC 300 – see the wiring diagram. If there are several external on/off switches, they should be parallel-connected.

Connection to a central computer.

The control panel can also be connected to a central computer, which gives a brief impulse (closure) between plinths 19 and 20 in the CC 10/ CC 50/ CC 100/ CC 300. The maximum permitted connection time for the sauna is 12 hours.

Figs. 27, 28, 31, Wiring diagrams.

(With sauna heater Deluxe and SE-U and control panel CC).

1 = sauna heater. 2 = thermistor (sensor). 3 = control panel. 4 = external on/off switch (if any). 5 = relay box.

Check the heater's type identification plate to ensure that the heater is connected to the right voltage. **Don't forget – The installation must be earthed!**

Unusual voltages or number of phases.

Before connecting the heater to a different voltage or number of phases than those described in the wiring diagram, contact Tylö Customer Service.

Building Instructions

The importance of correct sauna ventilation.

Incorrect sauna ventilation can result in hot floors and benches, scorched walls and ceilings (the temperature limit control is triggered)! So we do urge you to follow our instructions for sauna ventilation carefully.

Adjust the air outlet to evacuate 8-10.5 cubic yards. of air per person, per hour, when the sauna is in operation.

Mechanical sauna ventilation is not to be recommended, as the forced air supply can cause a fire hazard through the wooden panelling drying out.

Fig. 7. Sauna heater and door on the same wall.

The "air circulation" created by the door should work together with the hot air generated by the heater. To facilitate this, the heater should be placed on the same wall as the door (If exceptional circumstances require the heater to be fitted to a side wall, make sure it is located in close proximity to the wall with the door).

Fig. 14. Inlet vent always directly below the heater.

The inlet vent should be driven straight through the wall directly below the center of the heater. The cross-section of the vent for a family sauna is approx. 19 sq.in., for larger saunas approx. 46 sq.in. If possible, it is an advantage to have a shower on the other side of the wall. A flap valve may be fixed to the outside of the inlet vent to prevent water seeping into the wall.

Fig. 15. The outlet vent should never discharge directly into the open air.

Position the air inlet and outlet vents as far away from one another as possible (diagonally opposite). The outlet vent should be located high on a wall or in the ceiling, and should have the same cross-section area as the inlet vent. Spent air should always be led back into the same room from which it is drawn into the sauna – it must never be discharged directly into the open air. In this way, the air flowing from the sauna is continually being replenished in the room outside. This thermal ventilation method always works, no matter whether the pressure in adjacent rooms is negative or positive. If there is a gap above the sauna ceiling, do not seal it. To ventilate a cavity above the sauna, drill or cut at least one ventilation hole into the cavity through the wall on which the sauna door is located.

Alt. A: Outlet vent through the sauna wall (seen from above). The vent is placed high up, near the ceiling.

Alt. B: Outlet vent through the cavity above the sauna ceiling (seen from the side).

Alt. C: Outlet vent through a drum under the ceiling in the sauna (seen from the side). The outlet duct should be placed at an angle between the ceiling and the wall. The drum can be built of wooden panelling and have the same area as the outlet vent.

Special information for steam saunas (Combi-U and Tylarium):

Avoid placing the outlet vent so that it is led into a part of the building which is kept cold. This eliminates the risk for condensation.

Fig. 16. Recommendations for sauna construction:

- A. Floor frame, corner posts, studs, ceiling frame.
- B. Battens, rafters, vents.
- C. 3 in. mineral wool as heat insulation, approx. 3/4 in. air gap between insulation and outer wall.
- D. 1/2 in. wooden panel in walls and ceilings. There should always be at least 3 in. of insulation behind the wooden panel; no other material, such as particle board or plaster, may be used.
- E. Bonded, non-slip plastic floor-covering, extending approx. 2 in. up the walls behind the wooden panelling.
- F. Inlet vents should always be fully open. May be fitted with a shuttered vent on the outside.
- G. Outlet vent, can be fitted with a sliding hatch to adjust through-flow.
- H. Benches of at least 7/8 in. thick knot-free pine (alternatively aspen, lime or obeche).
- I. Drainage channel (recommended in public saunas). Never place a drainage channel or drain under the sauna heater.

Fig. 17. Heater guard.

The stones and the top of the sauna heater get very hot! In order to reduce the risk of accidental contact, Tylö always recommend that a heater guard be fixed as shown in the sketches.

Some words of advice:

- There should never be a drain in a sauna. However, all public saunas should have a drainage channel (I, fig. 16) connected to a drain out-side the sauna (no drainage channel is needed in a private sauna).
- If the sauna has a window in the door or wall, treat the lower molding with boat varnish and seal the joint between the glass and the molding with a water-resistant silicone sealant. This prevents any condensation on the glass from seeping into the wood.
- Varnish the threshold and door handles a few times with boat varnish to maintain the finish and simplify cleaning the sauna. Benches, decorative edging and back supports should be oiled on both sides with Tylö sauna oil (this is particularly important in the Tylarium).

Note: All other wood in the sauna should be untreated.

- Install floor decking only if the floor is slippery. Floor decking is impractical and prolongs the drying time for any water spilt on the floor.
- Treat the bucket and ladle with boat varnish, or oil them with Tylö sauna oil. The bucket will remain watertight and the wood will be beautifully preserved. Never leave the wooden bucket in the sauna after a sauna bath.
- Before you enjoy your first sauna bath, heat the sauna room up to 195°F and leave the heater to run for about 1 hour. This will rid the room of that “new” smell.
- Clean your sauna regularly. Scrub the benches and floor with soft soap. It is a mild, gentle detergent and leaves a pleasant fragrance.

General Information

Fig. 18. Filling the rock compartment.

Only use rocks of the dolerite type (Tylö sauna rocks), as “ordinary” rocks can damage the unit. Fill the rock compartment around the elements from bottom to top, stacking the rocks approx. 3 in. above the front edge at the top of the unit. Do not press the stones into place.

Fig. 19.

Never place stones above the side air chambers. This prevents air circulation, the unit becomes overheated and the temperature limit control is triggered.

Check the stone compartment at least once a year.

This is especially important for public saunas and saunas in frequent use. Remove all stones from the compartment. Clean any small stones, grit, gravel and chalky deposits from the bottom of the stone compartment. Use only stones which are whole and intact, replacing them when necessary with new dolerite stones.

Temperature limit control.

Tylö sauna heaters have a temperature limit control built into the terminal box on the heater. This is activated automatically if there is any risk of overheating. More often than not, the cut-off is triggered because of incorrect sauna ventilation or an incorrectly located sauna heater. Call an expert to reset the temperature limit control.

Fig. 20. Built-in humidifier (5.3 – 8.3 kW).

Fill the built-in reservoir with water before turning on the sauna, and you will have a pleasantly humid sauna right from the start, which accelerates and stimulates perspiration. You can also add a few drops of sauna fragrance to the water in the humidifier.

Sprinkling water on the stones

Should always be done with the ladle, never with a hose or bucket.

Note: The stones must be hot.

Operating Instructions SuperSport, Sport-U and TS

Temperature setting.

The Roman numerals indicate a rising temperature scale. Experiment to find the temperature that suits you best. Begin for example by turning the thermostat dial to position IV. If you later find that you would prefer a higher or lower temperature, adjust the dial up or down until you find the ideal bathing temperature for you (usually 160-190°F). Once you have found the right temperature, you can leave the dial on this setting.

How to use the timer.

As standard, the sauna heaters and control panels have a 60-minute timer without pre-set time.

Start the heater by turning the timer knob to the position “60”. The heater turns off automatically. You may turn the knob at any time back and forth to change the timing or turn off the unit.

Operating Instructions Combi-U

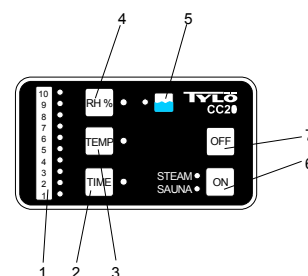

General

Functions.

1 = setting scale. 2 = time settings. 3 = temperature settings. 4 = humidity settings. 5 = water level LED. 6 = Green (on). 7 = Red (off).

Main power switch.

A mains switch on the base of the sauna heater can be used to interrupt the electricity supply to the heater. This switch should be used if the sauna will not be used for a longer period, such as several weeks. Note: The memory function must be reset each time the power has been interrupted.

Temperature setting.

(Unit in ON position)

Press TEMP – the previous temperature setting is displayed.

The numbers indicate a rising temperature scale. Experiment to find the temperature that suits you best. Begin for example by setting the temperature at position 4. If you find that you would prefer a higher or lower temperature, adjust the setting until you find the ideal bathing temperature for you (usually 158-194°F for traditional dry and wet sauna baths, 113-167°F for steam saunas and herbal saunas).

Humidity settings.

(Unit in ON position)

Press RH% – the previous humidity setting is displayed. The numbers indicate a rising scale. Experiment to find the humidity that suits you best. Begin for example by setting the humidity at position 4. If you find that you would prefer a higher or lower humidity, adjust the dial until you find the ideal humidity for you.

Note: The electronic control logic's limits the maximum humidity at given temperatures.

Timer settings.

(Unit in OFF position)

The numbers in this case represent the pre-set time setting (= the number of hours before the sauna heater automatically switches on). To set the timer:

Press TIME – to select the desired time, 1–10 hours.

Press Green (ON) – the timer is activated and the *time* LED flashes during the pre-set time period. The unit will start with the sauna settings that were last used. Once the sauna heater has been activated, it remains on for 1 hour, after which it automatically switches off. If you want to switch it off earlier, just press Red (OFF).

Traditional sauna bathing.

Dry and wet saunas

(158-194°F, 5-30 RH%)

Press Green (ON) – only the *sauna* LED should be lit. The memory function automatically sets the previous temperature and humidity (if any).

Press TEMP – if you want to change the pre-set temperature.

The built-in timer automatically switches the sauna heater off after 1 hour. If you want to switch it off earlier, just press Red (OFF). To extend the bathing time, press Green (ON) – only the *sauna* LED should be lit.

If you want steam production at traditional sauna bathing:

Press RH% – if you want to change the humidity setting. Setting 1 on the humidity scale = no steam production.

Adding water – fill until the water level LED shines steadily (a buzzer will sound – approx. 8 quarts). Use regular drinking water. Steam production will cease when the water level becomes too low and the level LED starts flashing (a pulsating buzz sounds).

The electronic control logic's will not begin the steam production until the selected bathing temperature is reached. The electronic control logic's automatically adjusts the humidity to given temperatures.

Steam sauna (Tylarium). (113-167 °F, 20-65 RH%)

Press Green (ON) – until the *steam* and *sauna* LEDs glow steadily. The memory function automatically uses the previous settings for temperature and humidity.

Press TEMP – if you want to change the temperature setting. (Setting 1 produces steam only).

Press RH% – if you want to change the humidity setting.

Adding water – fill until the water level LED shines steadily (a buzzer will sound – approx. 8 quarts). Use regular drinking water. Steam production will cease when the water level becomes too low and the level LED starts flashing (a pulsating buzz sounds).

The built-in timer automatically switches the heater off after 1 hour, and the automatic drying process is activated. The *steam* and *sauna* LEDs flash, even if you manually pressed Red (OFF).

The drying cycle lasts for about 20 minutes, after which the unit switches off completely. If you do not want to activate the drying process, press OFF again, but if you prefer to switch the heater on immediately after bathing time before the drying process commences, press ON – the *steam* and *sauna* LEDs will glow steadily.

To extend the bathing time after the heater has switched to the drying process (in other words, when both LEDs are flashing), first press Red (OFF) and then Green (ON). Both LEDs should then shine with a steady light.

Steam production only.

Choose settings according to above, then push TEMP – and select setting 1 on the temperature scale.

Important!

- If the sauna has a window in the door or wall, treat the entire lower molding with boat varnish and seal the joint between the glass and the molding with a water-resistant silicone sealant. This prevents any condensation on the glass from seeping into the joint.
- Sauna benches, decorative edging and back supports should be oiled on both sides with Tylö sauna oil.
- Never scatter sauna fragrance in the water inlet (A, Fig. 21) or in the herb bowl (B, Fig. 21). This will cause a heavy foam build-up and may trigger the temperature limit control (L, Fig. 4), or even cause a damage of the heating element. Empty the reservoir and rinse it clean of the fragrance, and then reset the temperature limit control.
- Fill the water inlet with drinking water (A, Fig. 21), until the water level LED shines steadily (a buzzer will sound – if you keep filling, the water will overflow). Steam production will cease when the water level becomes too low and the level LED starts flashing (a pulsating buzz sounds). If you want more steam, add more water, preferably hot. 1 quart of water is enough for approximately 20 minutes of steam production.
- To prevent a build-up of calcium deposits, empty the reservoir after each sauna bath. **WARNING:** The water is HOT! Disconnect the hose (M, Fig. 10), hold it up high and remove the plug. Lower the hose over a suitable vessel and empty the remaining water.
- De-scale the reservoir regularly with Tylö Solvent de-scaling agent. Switch on the heater (max humidity, min temperature) and let it run until the water in the tank begins to boil. Switch of the heater and wait for approximately 5 minutes Mix one bag (2.8 oz) with 4 quarts of water, pour it into the water inlet (A, Fig. 21). Leave the de-scaling agent to work for approximately 1 hour, then empty and flush the reservoir generously.
- Clean the herb bowl and fragrance cup regularly. Remove the entire top section and rinse it under running water. Clean the bottom of the reservoir as needed.
- During any steam bath, the outlet vent should always be closed or only slightly open.
- Open the air outlet fully after bathing. Once the automatic drying process has finished, leave the sauna door slightly open to give the room a proper airing.

How to get the most out of your sauna

- Take a towel in with you to sit on. Stay inside the sauna only as long as it feels pleasant. Go out now and then to cool off and freshen up with a quick shower.
- Show consideration for other bathers. Don't set the temperature higher than is pleasant for all those using the sauna.
- Young children love saunas. Let them splash about in a tub of water on the floor or the lower benches where it is somewhat cooler. But remember to keep an eye on them at all times.
- Round off your sauna with a long, cool shower.

- Never get dressed right after your sauna. This will only cause you to perspire. Relax, treat yourself to a cold drink and enjoy a sensation of true well-being. Don't get dressed until your body has cooled down and your pores have closed once again.

You can enjoy traditional dry and wet saunas with all Tylö heaters.

Dry and wet saunas are bathing forms whose history is shrouded in the mists of time. These hot baths are best enjoyed at temperatures between 160-190°F.

In **dry saunas**, where the stones are not sprinkled with water, the relative humidity (RH) is as low as 5–10%.

In **wet saunas**, when water is ladled on the hot stones from time to time, the relative humidity rises steeply to 10–25%, and you can feel how the quivering waves of heat massage their way into your skin. A few drops of Tylö Sauna Fragrance added to the water poured over the stones give a pleasantly invigorating sensation, clearing nasal cavities and helping you breathe more easily. A great way to round off any sauna is to experience the pleasant tingling sensation when you pour a little extra water over the stones. Wet saunas are considered by most people to be the traditional way to enjoy a sauna, and they are the most popular too.

Important! Use ordinary drinking water. Salt-water, swimming pool or spa water will damage the heating elements. Never hose down the heater. Devices that provide continuous water sprinkling are not permissible.

Steam and herbal saunas (Tylarium).

A steam sauna is a milder version, at only 113°F-158°F, and with a continual steam production that maintains a high relative humidity of 20–65%.

The sauna heater constantly adapts humidity levels to the chosen setting. You can change the humidity at any time using the RH button on the control panel. No matter what value you have set, you can also change the humidity by reducing or increasing the opening of the air outlet vent. To briefly increase the humidity, you can pour a ladlefull of water over the hot stones.

For a fragrant, refreshing herbal sauna, put some fresh or dried herbs and spices in the herb bowl (B, Fig. 21), then relax and enjoy the revitalizing scents in a steaming tropical climate. Test your own compositions: birch leaves, lavender, mint, spices, tea bags (!) and other exciting scents. You can also sprinkle a few drops of Tylö Sauna Fragrance in the scent cup (C, Fig. 21) – never in the herb bowl (B, Fig. 21) or the water reservoir (A, Fig. 21). There are six fragrances: Eucalyptus, Mint, Menthol, Pine, Lemon and Birch.

Tylö Sauna Fragrances can also be added to the water you splash over the stones.

Tylarium™

The unique combination of both traditional saunas and soft, mild steam baths in the same sauna room is also called Tylarium. Use the electronic control panel to select the kind of sauna you want, along with the desired temperature and time. Then sit back, relax and enjoy the exquisite bath. Once in a while, add some rejuvenating herbs or other balsam fragrances to create a new sauna sensation.

The widest range of Sauna Products

The Tylö range includes a host of fixtures and accessories for a more exclusive environment both inside and outside the sauna. For example, glass wall sections, veranda-style entrances with doors and windows, prefabricated sauna doors specially constructed to withstand the great variations in temperature inside and outside the sauna, ordinary sauna benches and those designed to cope with the more demanding environment of public saunas, comfortable back supports, decorative molding units, lighting and shades, fragrance dispensers and automatic water sprinklers.

In addition you will, of course, find sauna rocks, buckets, ladles, sauna fragrances, thermometers, hygrometers, hour glasses, wooden headrests, vent hatches and grilles, automatic sauna humidifiers and much, much more besides.

And for outside the sauna - a comfortable bench to rest on, and a couple of elegant deckchairs. Ask for the special brochures for Tylö Sauna Heaters/Accessories and Sauna Rooms where you will find detailed descriptions of all these attractive fixtures.

TYLÖ®

www.tylo.com

In the event of any problems, please contact the retailer where you purchased the equipment.

© This publication may not be reproduced, in part or in whole, without the written permission of Tylö. Tylö reserves the right to make changes in materials, construction and design.

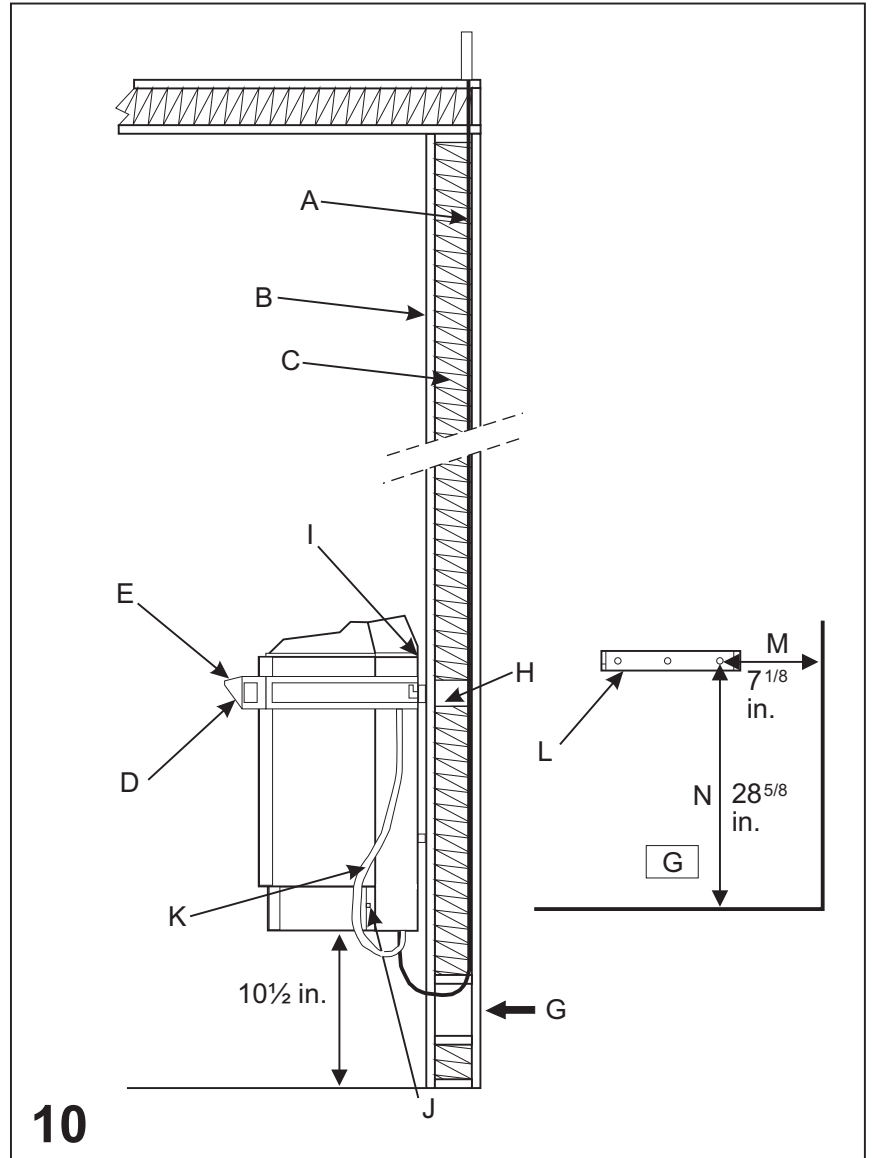
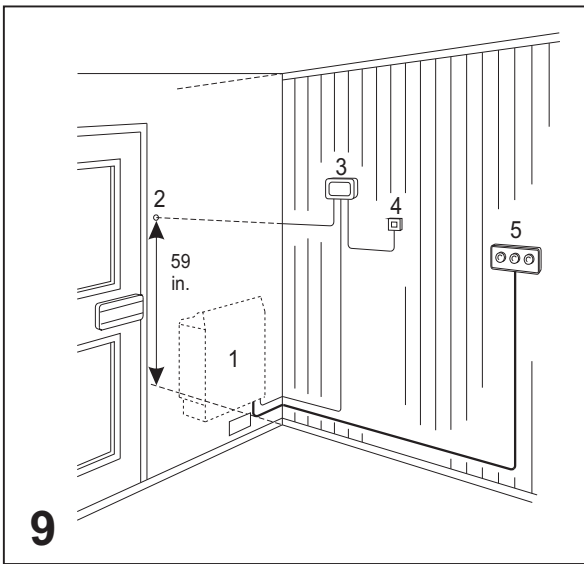
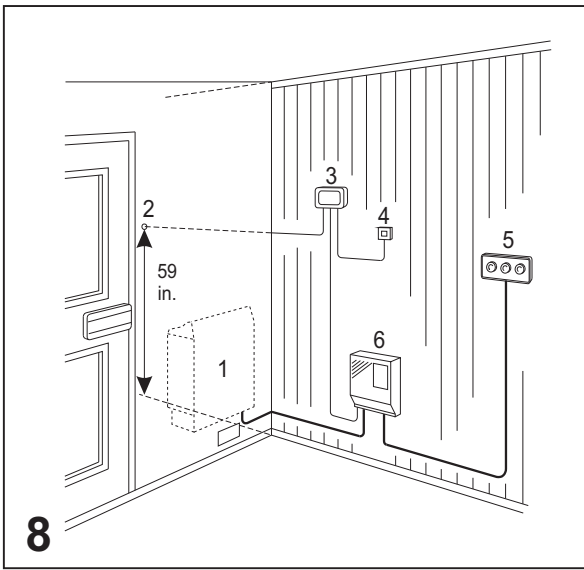
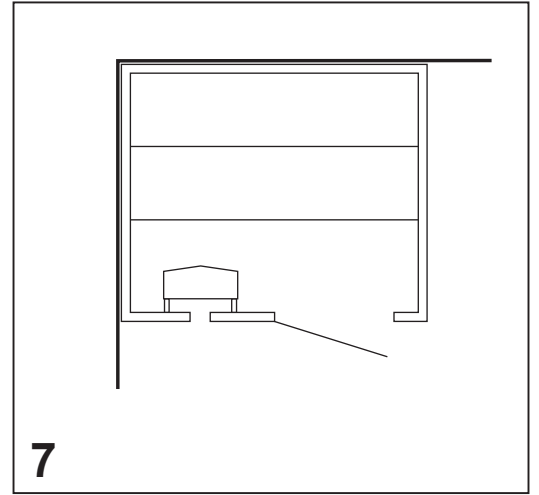
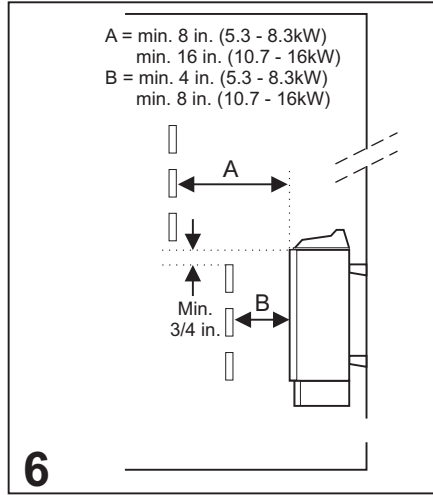
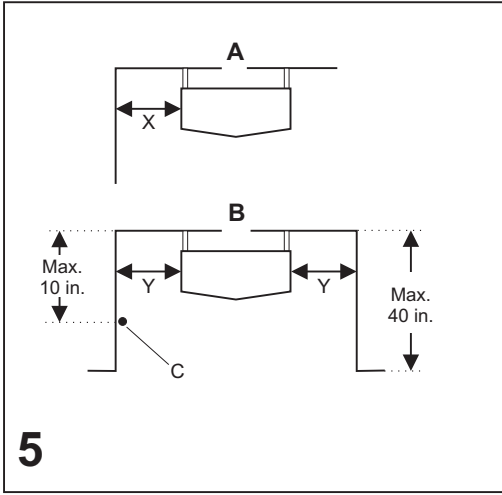
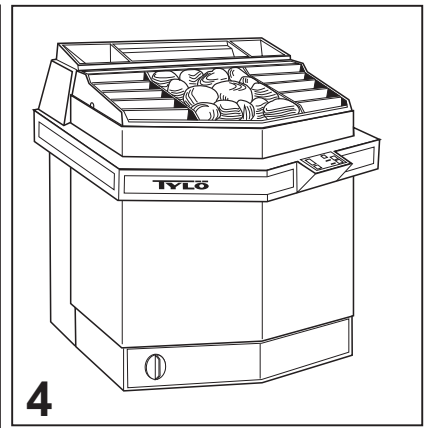
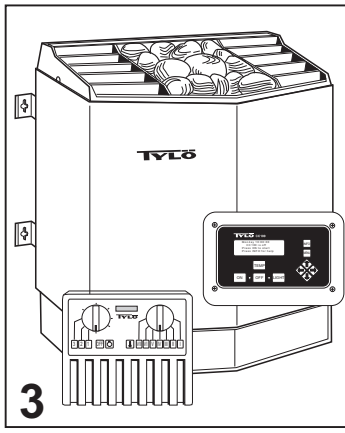
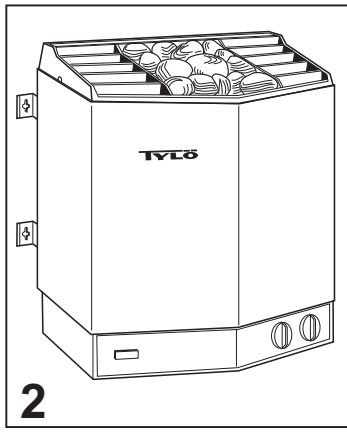
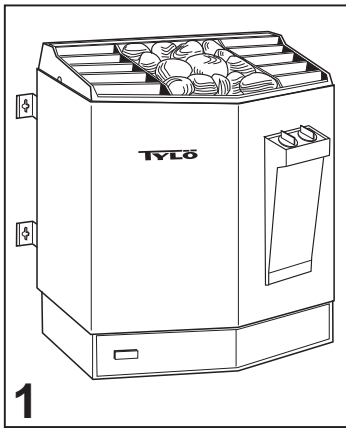

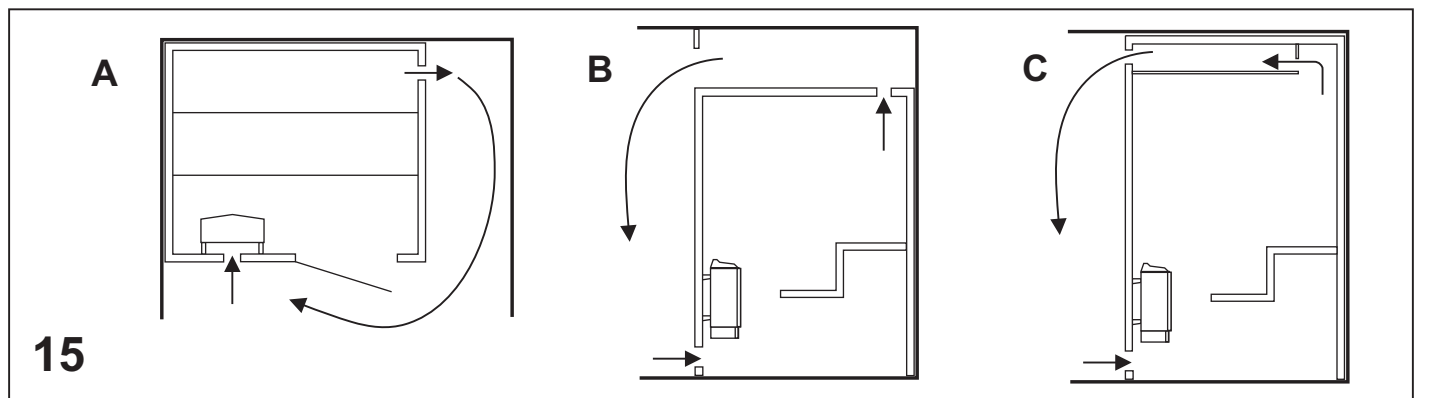
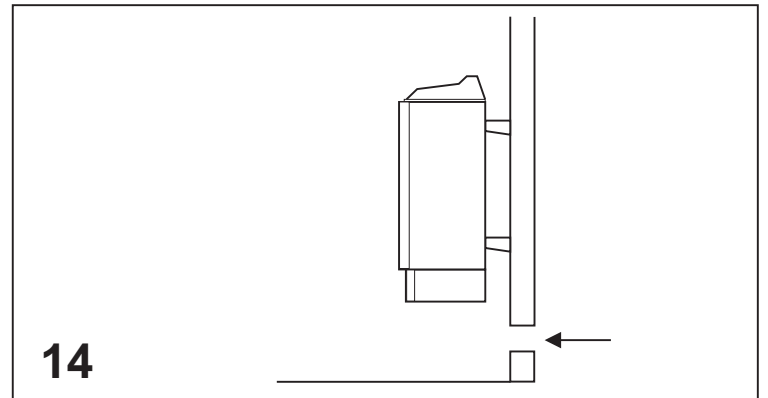
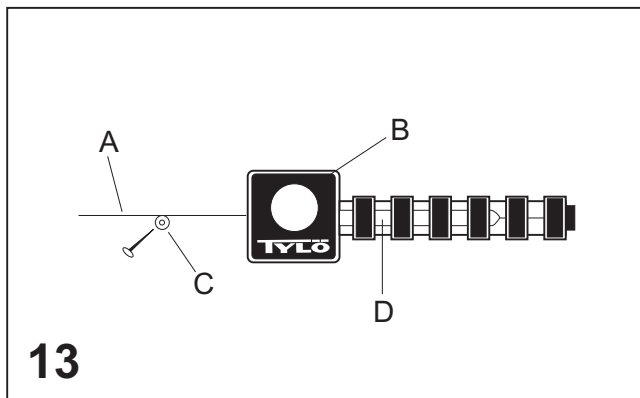
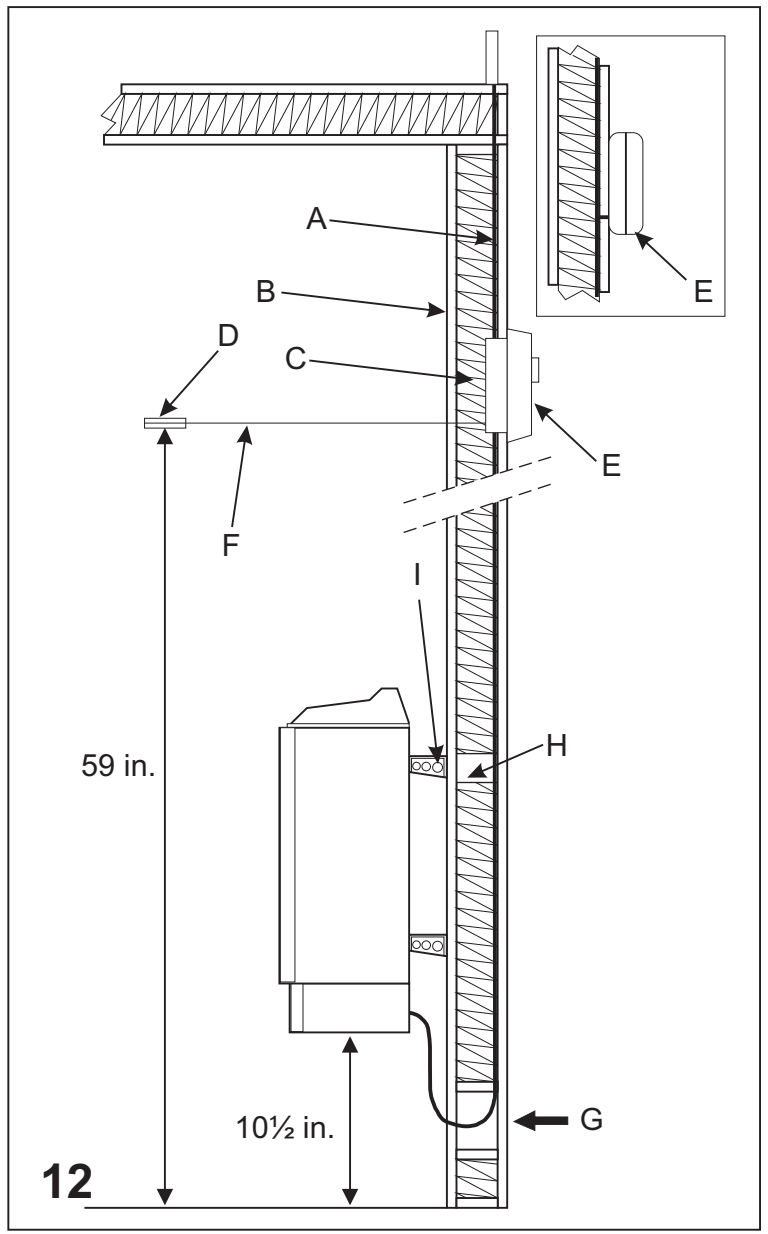
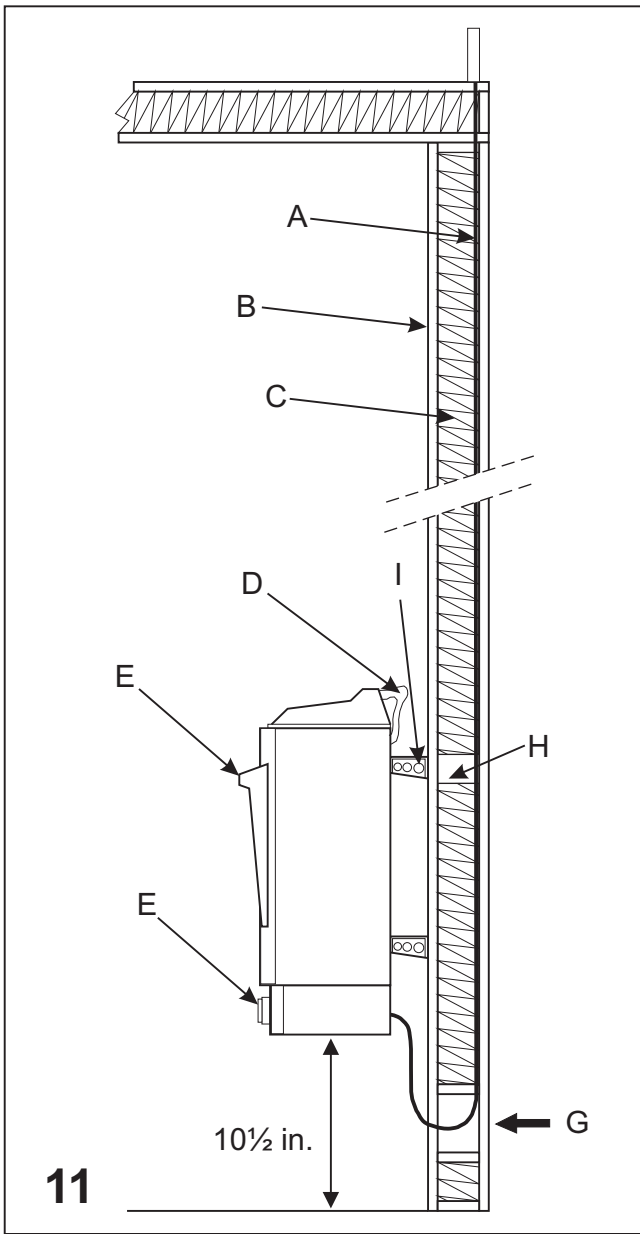

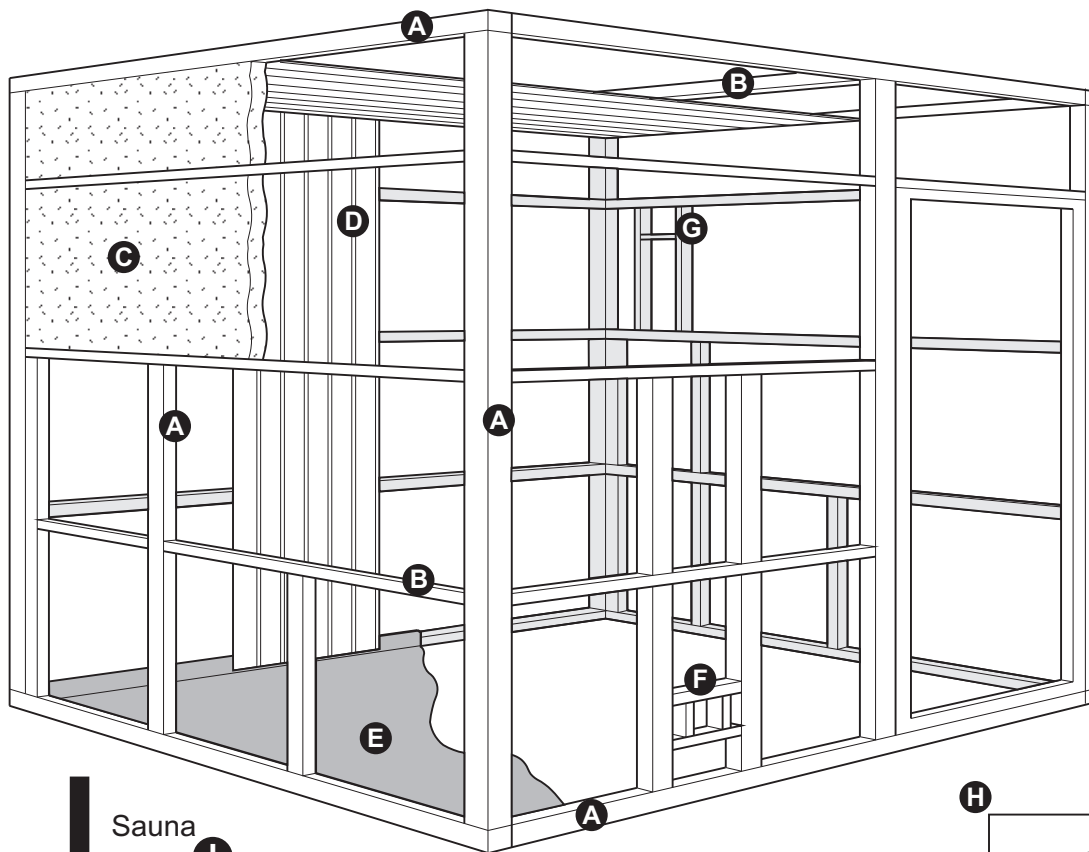

16

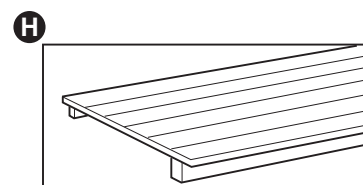
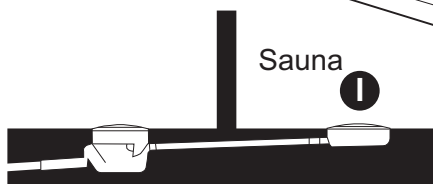

Alt A

A = min. 4 in. (2.2 - 8 kW)
min. 8 in. (10.7 - 16 kW)

Alt B

B = min. 8 in. (2.2 - 8 kW)
min. 16 in. (10.7 - 16 kW)

Min 3/4 in.

Max 8 in.

17

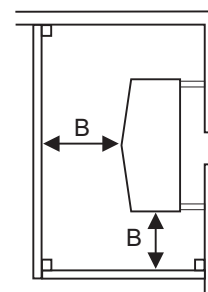
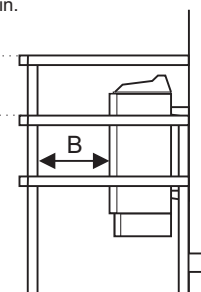
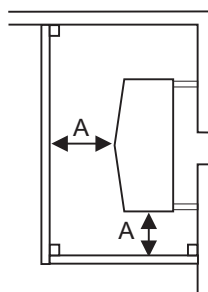
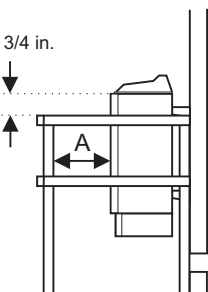

18

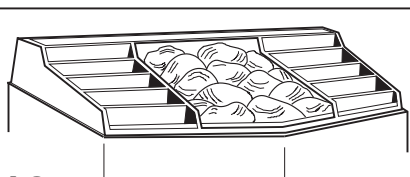

19

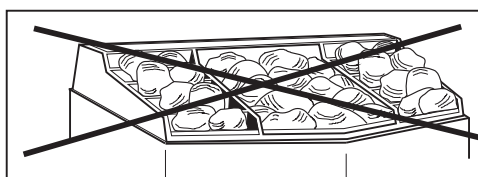

20

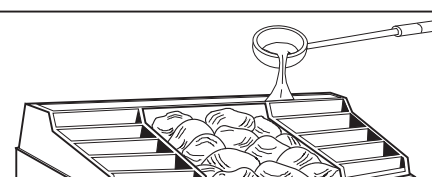

115 V~

240 V 1 ~

21

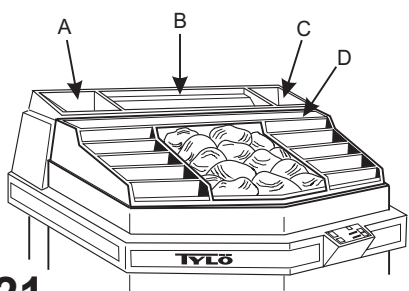

22 1 = Sport-U 2/4
Super Sport 2/4

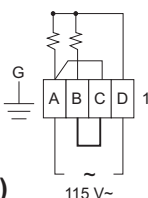

(2.2 kW)
115 V~

WARNING! THIS APPLIANCE MUST BE EARTHED!

23 1 = Sport-U 2/4
Super Sport 2/4

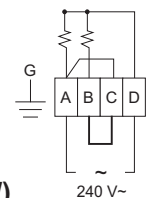

(4.5 kW)
240 V~

WARNING! THIS APPLIANCE MUST BE EARTHED!

24 1 = Sport-U 2/4
Super Sport 2/4

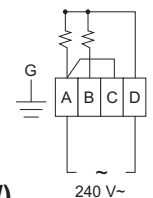

(2.2 kW)
240 V~

WARNING! THIS APPLIANCE MUST BE EARTHED!

208/240 V 1 ~

25 1 = Supersport 7-8
Sport-U 7-8
Combi-U 7-8

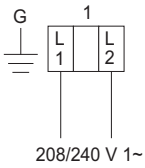

208/240 V 1 ~

WARNING! THIS APPLIANCE MUST BE EARTHED!

27 1 = Deluxe 7-8-11
2 = thermistor (sensor)
3 = CC10, CC50, CC100, CC300
4 = external switch
6 = RB 30

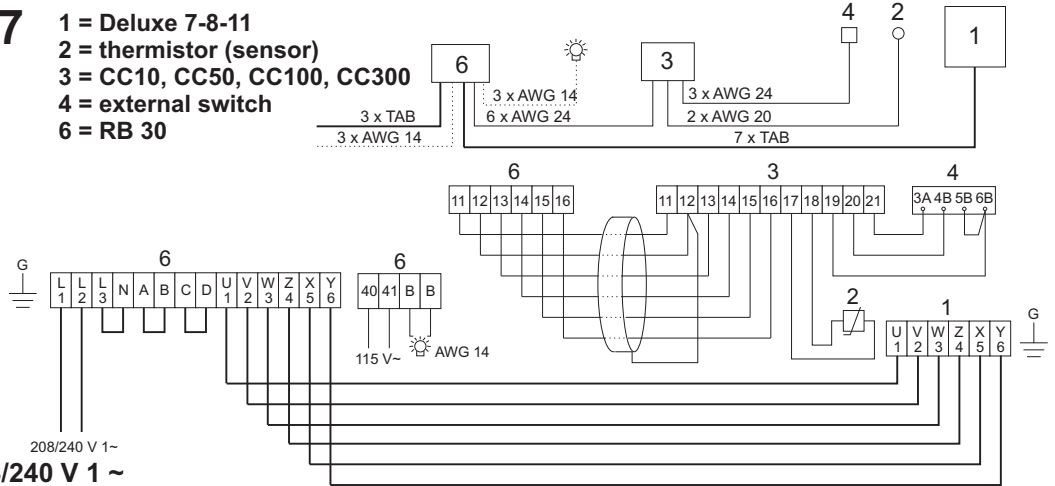

208/240 V 1 ~

WARNING! THIS APPLIANCE MUST BE EARTHED!

26 1 = Deluxe 7-8-11
2 = TS 30-01

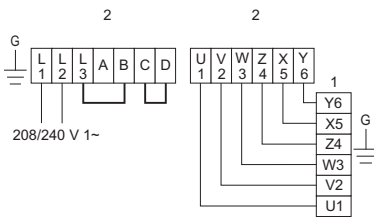

208/240 V 1 ~

WARNING! THIS APPLIANCE MUST BE EARTHED!

28 1 = SE-U 7, SE-U 8
2 = thermistor (sensor)
3 = CC10, CC50, CC100, CC300
4 = external switch

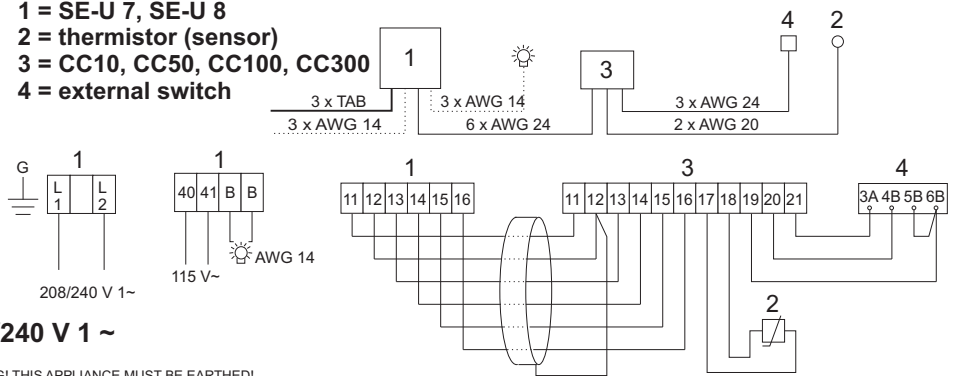

208/240 V 1 ~

WARNING! THIS APPLIANCE MUST BE EARTHED!

208 V 3 ~

29 1 = SuperSport 7-8
Sport-U 7-8

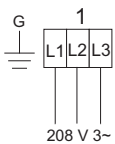

208 V 3 ~

WARNING! THIS APPLIANCE MUST BE EARTHED!

30 1 = Deluxe 7-8-11
2 = TS 30-01

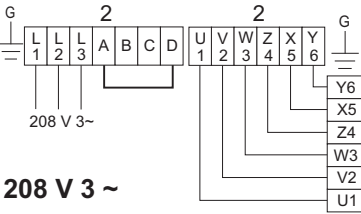

208 V 3 ~

WARNING! THIS APPLIANCE MUST BE EARTHED!

31 1 = Deluxe 7-8-11-16
2 = thermistor (sensor)
3 = CC10, CC50, CC100, CC300
4 = external switch
6 = RB 30, RB 60

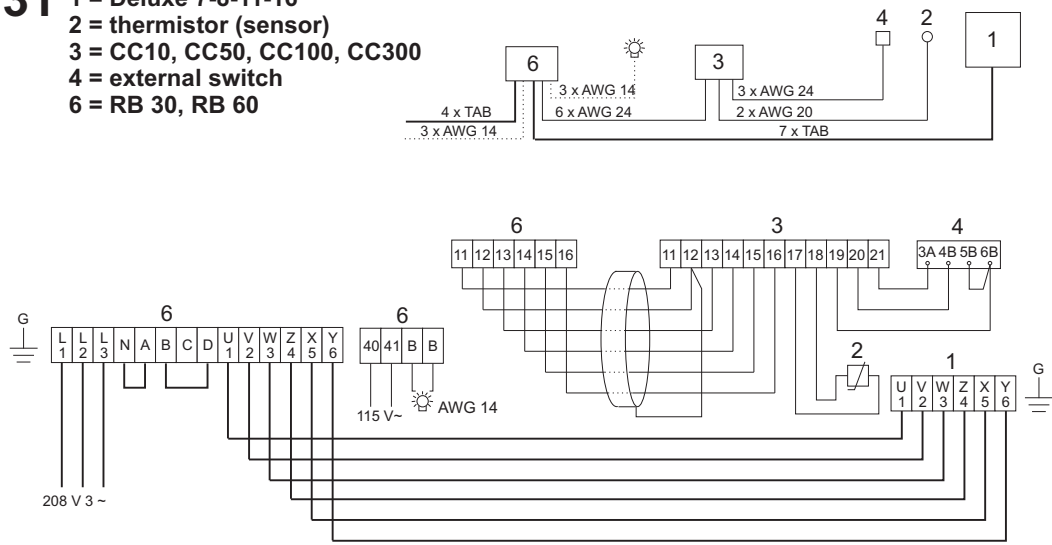

208 V 3 ~

WARNING! THIS APPLIANCE MUST BE EARTHED!